

# RENEGADE™14

Renegade 14 mechanical gooseneck lowbed  
Renegade N14 hydraulic gooseneck lowbed



## Your choice of mechanical gooseneck with fifth wheel guide rollers or hydraulic removable gooseneck models

- 30 tons capacity in 16 feet (35 tons evenly distributed) (GAWR and tire ratings determine legal payloads)
- 14" loaded center deck height (15" at rear) 5" ground clearance
- Generous flat level deck design lets you handle bigger loads for greater hauling versatility
- Sloped front ramp features traction cleats for easier loading and unloading
- Air-ride suspension with automatic and manual controls
- 2-part polyurethane enamel coating fights corrosion to extend trailer life
- LED lights, strobes, outriggers and D-rings are all standard to give you more trailer for your money



Optional hydraulic removable "shaft & hook" gooseneck is the fastest and most versatile in the industry—especially on uneven ground.



Standard liquid-filled air gauge helps you position the load quickly, easily and accurately.



Low profile connections for optional 3rd axle give you even greater hauling versatility.

[www.fontaineheavyhaul.com](http://www.fontaineheavyhaul.com)

Fontaine Heavy-Haul • 5398 US Highway 11 • Springville, AL 35146 • 205-467-6171

Weights shown are without options • Photos may show some optional equipment • Specifications subject to change without notice

# Fontaine Renegade® 14/N14 Specifications

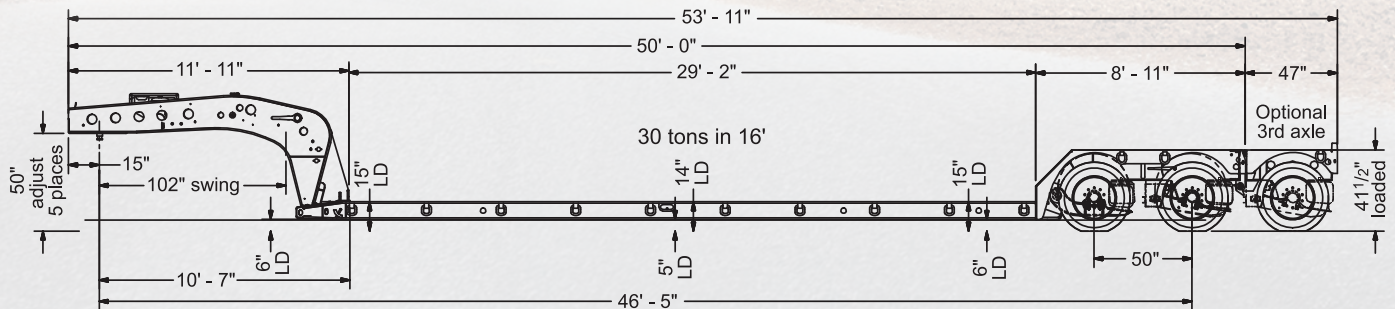

## CAPACITY

- 30 tons in 16 feet and 35 tons evenly distributed (GAWR and tire ratings determine legal payloads)

## MAIN BEAMS

- All main longitudinal members fabricated with 100 KSI minimum yield steel flanges with 50,000 lb. webs

## LOADED FIFTH WHEEL HEIGHT

- Figure-eight plate features 50" loaded height

## REMOVABLE GOOSENECK FEATURES

- **Mechanical** design with fifth wheel guide rollers and full-width platform with 1 1/8" apitong for greater loading space (includes aluminum fenders at rear of platform)
- Optional **Hydraulic** non-ground bearing design
- 50" loaded fifth wheel height
- Swing radius: **Mechanical** 81", **Hydraulic** 102"
- J560 7-pin electrical connector

## DECK FEATURES

- 14" loaded deck height with 5" ground clearance
- Front of deck is sloped and features traction cleats to make loading and unloading easier
- Full-width 2" apitong flooring
- Crossmembers on 24" centers for greater strength and durability

## BOGIE FEATURES

- Covered rear bogie platform with 1 1/8" apitong or equivalent flooring
- Fixed deck-to-bogie connection with full-width bogie ramp
- Connections for future axle (including air and electrical)

## AXLES

- 2 heavy-duty axles with 50" spread
- Air/electrical connections in place for easy third axle connection
- 25,000 lbs. nominal capacity per axle (GAWR determined by suspension type, brakes, tires and other components)
- Tapered spindle axles, automatic slack adjusters and spring brakes

## 4S/2M ANTILOCK BRAKE SYSTEM

- ABS wired to center pin of 7-way socket
- Electronic sensors at every wheel end
- Virtually eliminates tire flat-spotting

## BRAKES

- Spring brakes (2 axles)
- 16 1/2" x 7" with 5 1/2" autoslacks
- Heavy-duty brake drums, outboard mount
- Quick change replacement feature saves repair time
- Automatic slack adjusters maintain positive braking action

## HUBS

- Hub-piloted 10-stud mount for increased capacity and durability
- Outboard cast drums save time and cost on brake repairs



## WHEELS/TIRES

- Wheels: 8.25 x 22.5 steel disc, hub-piloted
- Steel disc wheels (optional wheels available)
- Tires: 255/70R 22.5 OEM Standard

## SUSPENSION

- Unitized air-ride suspension with automatic and manual controls
- Suspension mount is engineered, reinforced and braced to virtually eliminate frame cracking

## ELECTRICAL SYSTEM

- Sealed harness for maximum corrosion resistance
- DOT sealed beam with LED lights
- 4" flush mounted, battery powered amber strobes

## PROTECTIVE COATING

- Highest quality 2-part polyurethane enamel fights corrosion to extend the life of your trailer
- Shot blasted and cleaned prior to painting
- Primed for better paint adhesion

## LASH RINGS

- 12 pair, 24 total

## FLAG HOLDERS

- 3 pair (6 total)

## ESTIMATED EMPTY WEIGHT W/O OPTIONS:

18,405 lbs. ± 3% (weight shown for **Mechanical** gooseneck model)

Specifications subject to change without notice.  
Photos show some optional equipment.

[www.fontaineheavyhaul.com](http://www.fontaineheavyhaul.com)

Fontaine Heavy-Haul • 5398 US Highway 11 • Springville, AL 35146 • 205-467-6171

Weights shown are without options • Photos may show some optional equipment • Specifications subject to change without notice